



Studio

Freestanding Range



Installation & Servicing Instructions

For use in AU & NZ (Australia and New Zealand)

These products are tested in accordance with AS/NZS 4012:2014, AS/NZS 4013:2014 and AS/NZS2918:2018 and comply with emission requirements for Australia when using Hardwood.

IMPORTANT

THE OUTER CASING, FRONT AND GLASS PANEL BECOME EXTREMELY HOT DURING OPERATION AND WILL RESULT IN SERIOUS INJURY AND BURNS IF TOUCHED. IT IS THEREFORE RECOMMENDED THAT AN APPROVED FIREGUARD IS USED IN THE PRESENCE OF YOUNG CHILDREN, THE ELDERLY OR INFIRM.

CAUTION: THIS APPLIANCE SHOULD BE MAINTAINED AND OPERATED AT ALL TIMES IN ACCORDANCE WITH THESE INSTRUCTIONS.

Keep them in a safe place for future reference and when servicing the fire.
The commissioning sheet found on page 3 of these instructions should be completed by the Installer.

CONTENTS

Studio Freestanding

Covering the following models:

RVFST-2HTAU

Appliance Commissioning Checklist	3
Essential Information	4
Dimensions	5
Installation Instructions	6
Installation Checklist	6
Removing Internal Components	8
Installing the Appliance	10
Commissioning	15
Maintenance & Servicing	16
Annual Service	16
Removal of Internal Parts	17
Fitting A New Door Seal	17
Adjusting Door Hinges	17
Adjusting the Door Catch	18
Technical Appendix	19
Legal Requirements	19
Flue Outlet Positions	20
Flue & Chimney	22
Ventilation	23
Minimum Dimensions - Floor Protector	23
Fire Surround Clearances	23
Spare Parts List	24
Service Records	26
Warranty	27

APPLIANCE COMMISSIONING CHECKLIST

This checklist **MUST** be filled out completely and signed in order to qualify for the full Dealer Warranty. Failing to complete this commissioning checklist will mean the warranty will only be valid for 12 months from the date of purchase.

Dealer appliance was purchased from:

Name: _____

Address: _____

Telephone number: _____

Essential information - MUST be completed:

Date Installed: _____

Model Description: _____

Serial Number: _____

Installation Technician:

Company Name: _____ AHHA/SFAIT License No _____

Address: _____

Telephone number: _____

Commissioning Checks - to be completed and signed:

Is flue system correct for the appliance:	YES <input type="checkbox"/>	NO <input type="checkbox"/>
Flue swept and soundness test complete*:	YES <input type="checkbox"/>	NO <input type="checkbox"/>
Smoke test completed on installed appliance	YES <input type="checkbox"/>	NO <input type="checkbox"/>
Spillage test completed	YES <input type="checkbox"/>	NO <input type="checkbox"/>
Use of appliance and operation of controls explained	YES <input type="checkbox"/>	NO <input type="checkbox"/>
Clearance to combustible materials checked**	YES <input type="checkbox"/>	NO <input type="checkbox"/>
Instruction book handed to customer	YES <input type="checkbox"/>	NO <input type="checkbox"/>
CO Alarm Fitted (Recommended)	YES <input type="checkbox"/>	NO <input type="checkbox"/>

*If using an existing flue system - not applicable for a new flue assembly
 ** Record with photographs if possible.

Signature: Print Name:

ESSENTIAL INFORMATION

GENERAL	Model:			Studio 2
	Studio 2			
	Nominal Heat Output	Wood	kW	8.7
	Room Heating Capacity	Wood	m ²	180
	Particulate Emissions	Wood	g/kg	1.2
	Efficiency	Wood	%	62%
	Weight		Kg	135
Recommended Fuels	Wood	Seasoned Wood (less than 20% moisture content) Hardwood		

As tested to the requirements of AS/NZS 4012:2014 & AS/NZS 4013:2014.

FLUES	Flue/Chimney Size	Factory made system (diameter) installed in accordance with manufacturers instructions	mm	150/200/250
		Masonry Installation flue liner (diameter)	mm	150
	Flue/Chimney minimum height**	All products	m	4.6
	Flue Draught	Min	mm Wg	1.0
		Nominal		1.5
		Max		2.0
Flue Outlet Size		mm	153	

Flue Specification approved to AS/NZS 2918:2018

VENTILATION	Room Air Replacement (vents x 2)	mm	175 x 175 x 2
--------------------	--	----	---------------

For full technical details on ventilation see Technical Appendix.



****When measured from the top of the appliance to the top of the flue, with no horizontal sections and a maximum of 4 bends with angles of less than 45°**

PLEASE NOTE

This section is intended to give an overview of the product performance and essential information required for installing the appliance. It is intended for a qualified professional who is already familiar with Stovax products.

For full details and expanded information please see the Technical Appendix at the back of this manual.

STUDIO DIMENSIONS

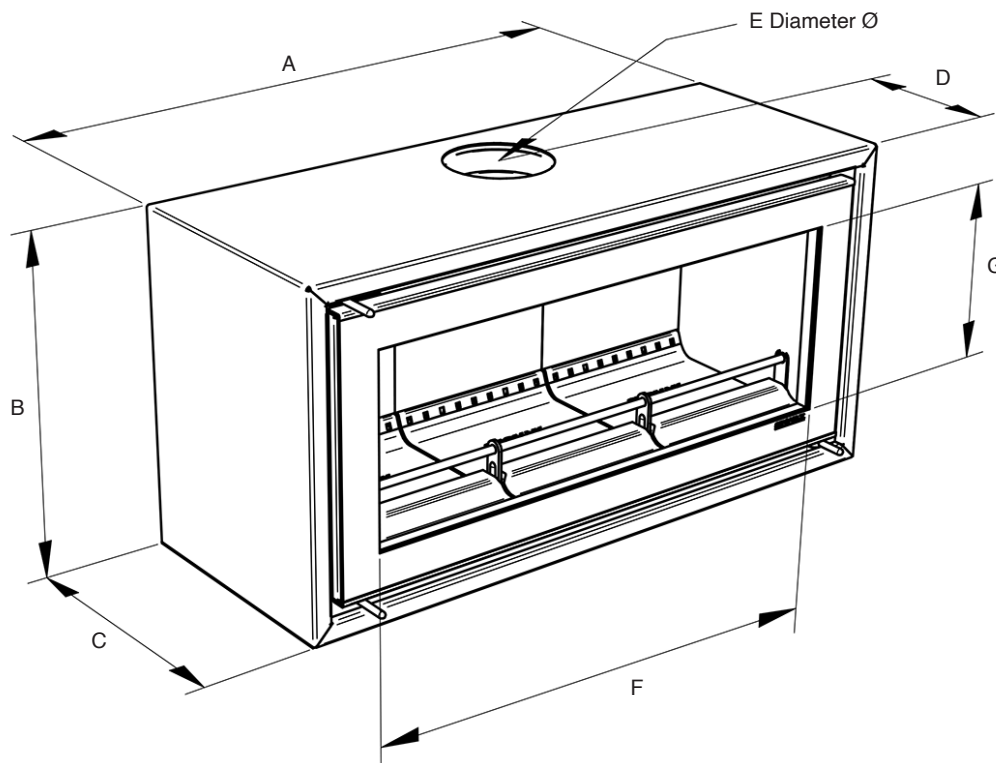

DESCRIPTION	MODEL	A	B	C	D	E	F GLASS VIEWING AREA	G GLASS VIEWING AREA
STUDIO 2	RVFST-2HTAU	1000	504	380	260	153 (6")	790	289

All dimensions in mm. (25.4 mm = 1")

INSTALLATION CHECKLIST

MINIMUM DIMENSIONS - FLOOR PROTECTOR

FLOOR MOUNTED

If the appliance is installed directly onto the floor it must stand on a heat resistant constructional floor protector and the minimum dimensions shall meet the requirements of AS/NZS2918:2018.

BENCH MOUNTED

If this appliance is installed on a Stovax Bench, the bench must stand on a heat resistant floor protector, see Diagram.

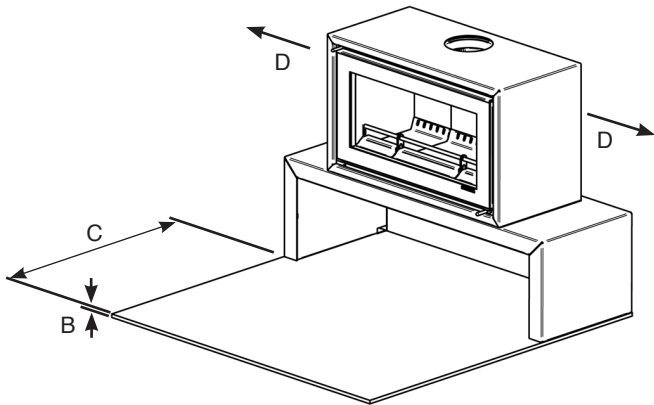

STUDIO 2 FLOOR PROTECTOR DIMENSIONS (mm)

B (Thickness)	24
C (350 High Bench)	300*
D - Side	200**

* measured from the front of the appliance

** measured from the side of the appliance to edge of protector

If installed in any other configurations the default values listed in AS/NZS2918:2018 section 3 must be used.

The building must have a suitable load-bearing capacity for the floor protector and appliance. Consult a structural engineer for advice before proceeding.

When fitting into an existing floor protector check that the appliance complies with current construction regulations and is at least the minimum sizes shown.

If there is no existing floor protector and chimney it is possible to construct a suitable heat resistant housing and floor protector setting. The flue must be installed in accordance with all local and national regulations and current rules in force.

OPTIONAL EXTRAS

BENCH

This appliance can be fitted with a bench, various sizes are available. This must be done at the time of installation. Please refer to instructions - PM205.

HEAT SHIELD

This appliance can be fitted with a heat shield in order to decrease the distance the appliance can be installed from a wall. This must be done at the time of installation. Please refer to instructions - PM732AU.

CLEARANCES

IMPORTANT: INSTALLATION MUST COMPLY WITH CURRENT BUILDING REGULATIONS



ENSURE THAT SUFFICIENT CLEARANCES ARE PROVIDED BETWEEN THE FLUE PIPE AND ANY HEAT SENSITIVE MATERIALS IN THE FIREPLACE IN ACCORDANCE WITH THE RULES IN FORCE.

When installing a Studio stove it is important to observe the following clearances to both **heat sensitive** and **heat resistant** materials. Also ensure that a clearance of 1 meter is maintained in front of the appliance when operating.



DEFINITIONS FOR MATERIALS USED IN ACCORDANCE WITH AS/NZS2918:2018 STANDARD:

Heat-resistant material

- A material with an allowable service temperature of 600°C or greater.

Heat-sensitive material

- A material with an allowable service temperature less than 150°C.

Heat-tolerant material

- A material with an allowable service temperature greater than 150°C but less than 600°C.

FIREPLACE: MINIMUM CLEARANCES ABOVE & TO THE SIDES (ELEVATION VIEW)

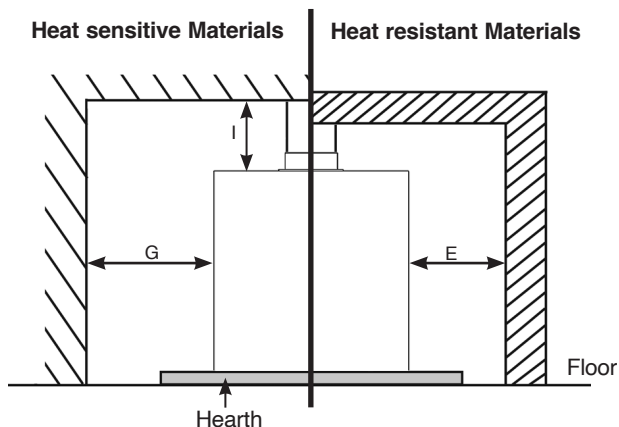

HEAT SENSITIVE MATERIALS

It is essential for safety to ensure the following clearances to heat sensitive materials are maintained.

See Minimum Clearances and table below.

MODEL	G (SIDE)	H (REAR)	I (ABOVE)**
	(mm)		
STUDIO 2	425	375	1500

** F - Default clearance AS/NZS2918:2018 3.2.2 Safety Clearance.

* C/B - Default clearance AS/NZS2918:2018 3.2.1 Access Clearances.

HEAT RESISTANT MATERIALS

The appliance must be installed a minimum distance from any surrounding walls to meet the requirements of AS/NZS2918:2018. See Diagram and table below.

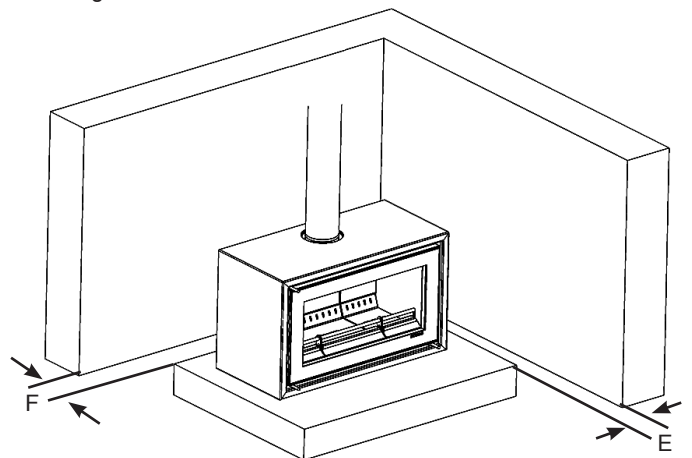

MODEL	DIMENSION F*	DIMENSION E*
STUDIO 2	100	100

All dimensions in mm. (25.4 mm = 1")

FIREPLACE: MINIMUM CLEARANCES TO THE REAR (PLAN VIEW)

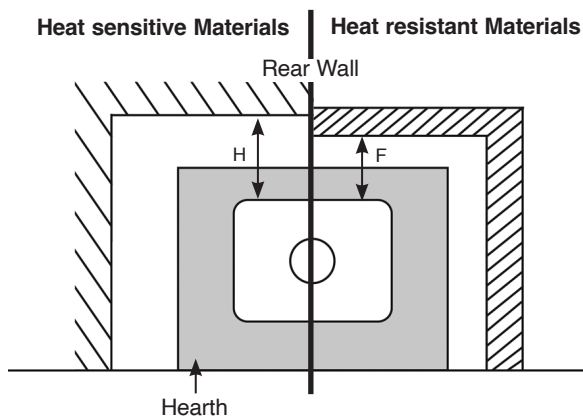

REMOVING INTERNAL COMPONENTS

GENERAL

To make the installation of the appliance easier it is best to remove the internal components before fitting into the builders opening/studwork.

For the best results removing the following components as set out below.

REMOVAL OF THE DOOR

Before removing the door it is recommended to protect the left edge from damage using masking tape.

Open the door approximately 90°.

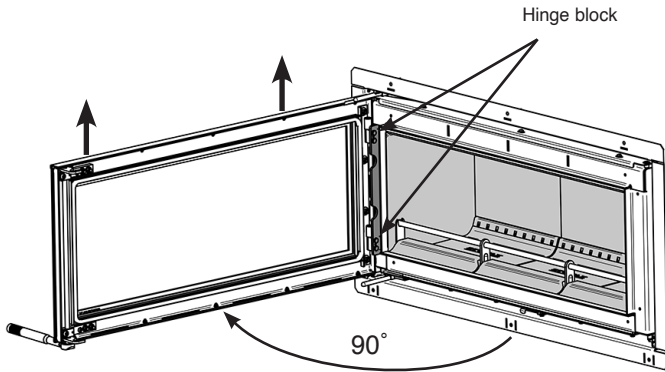

Move the Air Control to the far right.

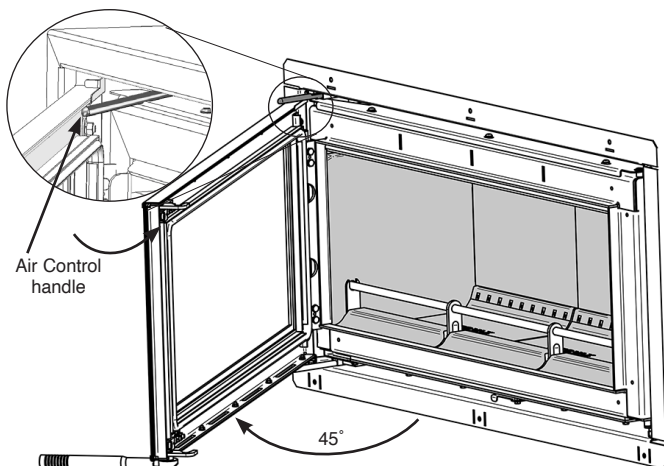

Lift the door vertically to remove from the hinge block.

Close the door 45°, ensuring the Air Control handle sits inside the channel in the top of the door and carefully manoeuvre the door clear of the hinge mechanism.

Lie the door face down on a soft flat surface to protect the paint work and glass.

Reverse the procedure to re-fit the door.

REMOVAL OF INTERNAL COMPONENTS

In the firebox of the Studio are several loose items including:

- A box containing:
 - Baffle Bricks
 - Firebricks
 - Bag containing Instruction Manual, Warranty &
 - Door Tool.
- Log Guard End Supports
- Log Guard
- Front Baffle Support
- Leather Gloves

Remove these carefully and put them safely to one side. They can be fitted after the appliance has been installed, see Installation Section.

REMOVAL OF THE TOP BAFFLES

The appliance is fitted with 2 baffles in the top of the firebox to maintain efficient combustion.

Once the loose internal components have been removed it is possible to remove the metal Top Baffles.

Allow the appliance to cool fully before removing the baffle system.

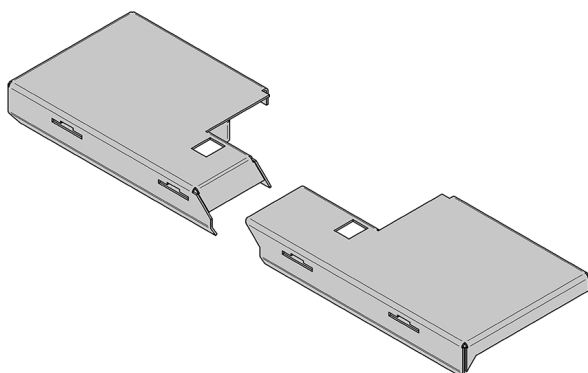

The Studio 2 baffle comes in two sections. To remove the baffle system first disengage the left hand side. The method of removal is the same for both sections.

Use two hands and lift the front edge of the baffle to clear the support tabs at the front of the firebox. Push the baffle towards the back of the appliance to free it from the tabs at the front.

Lower the baffle into the firebox to disengage from the support pins and carefully withdraw through the front of the appliance. **Take care not to damage the firebricks.**

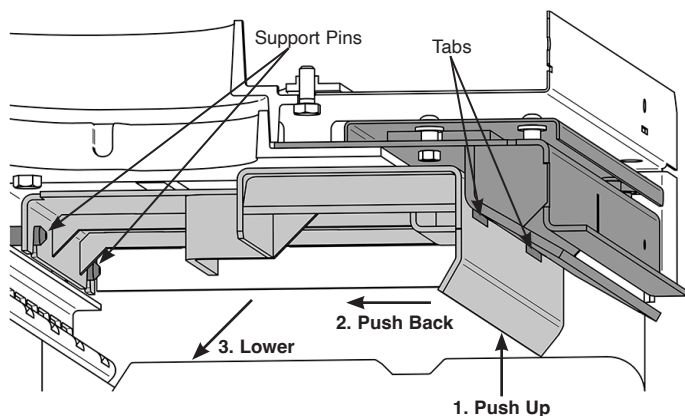

If the appliance has more than one baffle remove in the correct order.

Replace in reverse order.

The baffle system is designed to give safe and efficient operation of the stove. Replace damaged baffles immediately.

Do not modify the baffle system.
Do not operate with the baffle system removed.

SEPARATE THE INNER & OUTER BOX

To protect the delicate parts of the appliance the product has been designed so that the inner box can be removed from the outer box. Keep the inner box in a safe place whilst the outer box is installed into the fabric of the house, the main flue connections made and the walls finished.

When all the heavy work is complete the inner box can be re-installed into the outer box and the final connection made.

The internal components, bricks, baffles and the door etc should be removed to make the installation process easier and prevent damage.

First remove the inner collar.

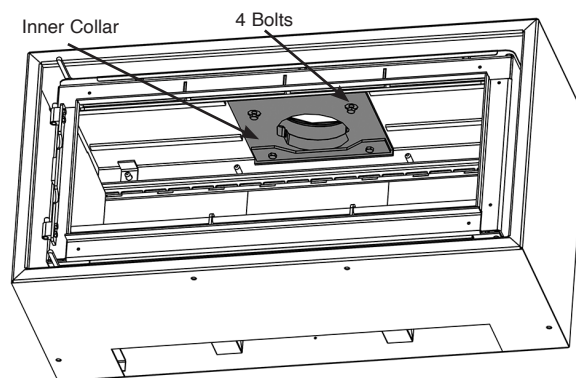

First remove the inner collar. Using a 13 A/F spanner, remove the 4 x bolts.

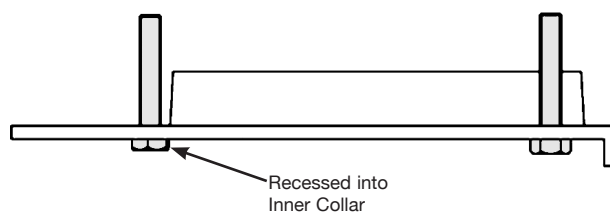

The inner box can now be slid out of the outer box. **There is a roller assembly at the rear which locates in cutouts on the outer box.**

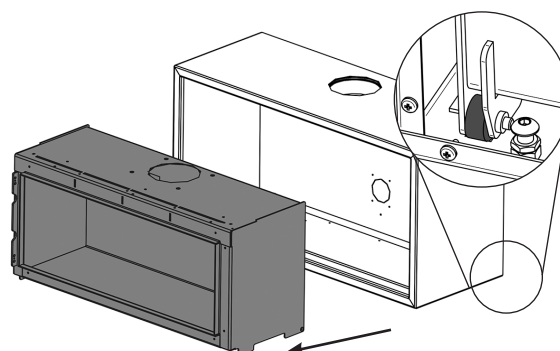

Pull the inner box carefully forward to release from the cutouts. It should now slide smoothly out of the outer box. This will require at least two people.

INSTALLATION INSTRUCTIONS

GENERAL POINTS

Each installation is unique to the property so it is not possible to give details to suit every setting. The installation must comply with Building Regulations and be made using "best practice" construction methods.

Stovax Studio appliances can reach high temperatures so it is important to maintain the clearance to heat sensitive materials and ensure the housing for the appliance is built from heat resistant material.

Take care when installing the appliance. Careless handling and use of tools can damage the finish and/or area.

Other heat resistant materials may also be used to create a housing for the appliance but it is essential to maintain the clearances to heat sensitive material.

i **NOTE: If installing a Heat Shield, please consult manual PM732AU prior to installation.**

THIS APPLIANCE MUST BE SECURELY BOLTED IN POSITION TO SUPPORT THE DOOR WHEN IT IS OPENED.

Use M6 or M8 bolts to secure the outer case to the masonry of the fireplace. There must be at least two bolts in the back of the outer case and one in either side. These can be secured through the side or base of the outer case (see shaded area in Diagram below). Check the security of these fasteners before proceeding to fit the inner box.

BOLTING APPLIANCE TO THE HEARTH

The appliance must be fixed to the hearth. Use the four hearth mount holes shown in Diagram.

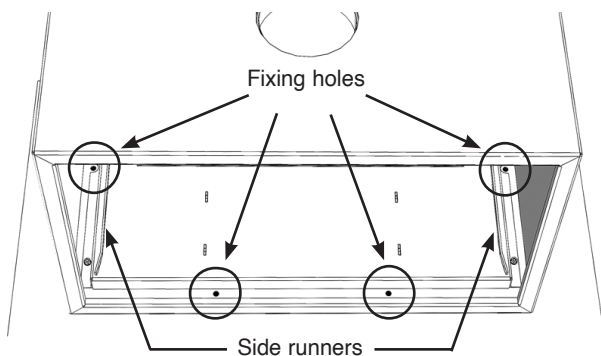

Take care not to damage the hearth.

- Position the appliance where required on the hearth and mark the location of the 4 fixing holes in the outer box.
- Drill the right sized holes into the hearth.
- Use suitable fasteners to fix into place.

i **The fixing above must also comply with AS/ NZS 2918:2018 section 3.8 for seismic restraint. Earthquake restraints may be positioned by drilling through the firebox into the base of the box within the shaded area using 2 x M8 bolts or similar. Do not over tighten and deform the firebox.**

INSTALLATION OF THE INNER BOX

NOTE: This will require 2 people.

Slide the inner box into the outer box.

There is a roller assembly at the rear of the inner box which locates in cutouts in the base of the outer box.

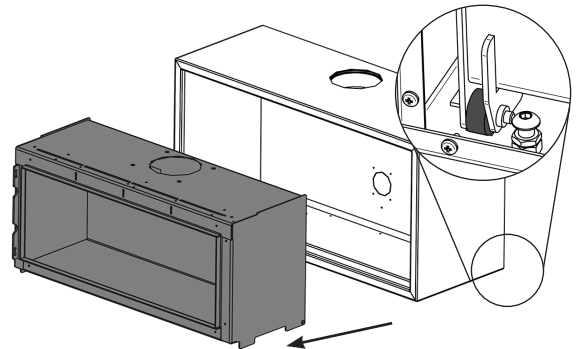

Apply fire cement in to the faces shown in Diagram prior to fitting the inner collar.

Inner Flue Collar

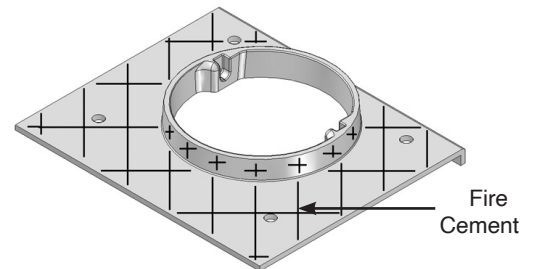

Fit the inner flue collar using the 4 x bolts. Ensure that all bolts are finger tight only.

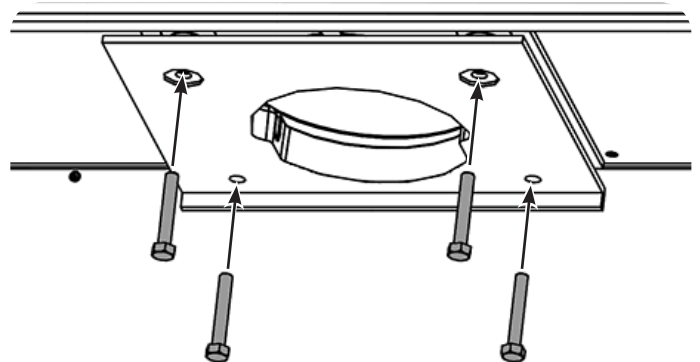

TOP FLUE INSTALLATION

If not already fixed to the hearth, move appliance into position, taking care not to damage the hearth finish.

Connect appliance to chimney using flue pipe:

- i**
- 1) Install first length of flue pipe crimped end down, inside gather collar.
 - 2) Rivet flue pipe in 3 places around gather collar.
 - 3) Place bottom flue spider bracket around gather flue pipe collar, secure in position by tightening up coach bolt/screw (supplied).
 - 4) Install second length of the flue pipe crimped end down and fix by riveting in at least 3 places around the flue pipe joint.
 - 5) Install first length of the flue pipe casing by positioning on installed bottom flue spider bracket crimped end up.
 - 6) Position flue spacer at the flue pipe joint.
 - 7) Repeat steps 1 - 4 to the required flue height.

Seal the connecting joints.

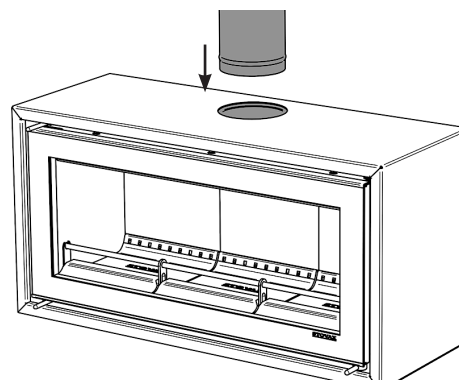

The flue must be installed in accordance with the manufacturers instructions.

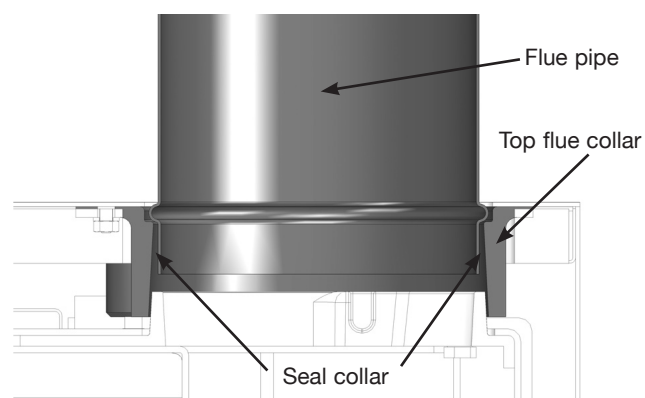

From the top of the appliance, place a generous amount of fire cement inside the top flue collar.

Note: The Top Flue Connection should meet the requirements of AS/NZS2918:2018 Section 4.

Insert the 612mm long flue pipe into the flue collar so that the bulge is inside the flue collar and resting on the ledge

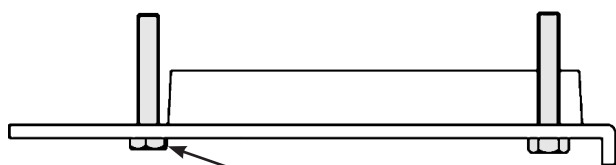

Recessed into Inner Collar

Check that the front of the inner box is parallel to the outer box. Adjust the position until correct and then fully tighten the 4 x bolts. Do not over tighten the bolts.

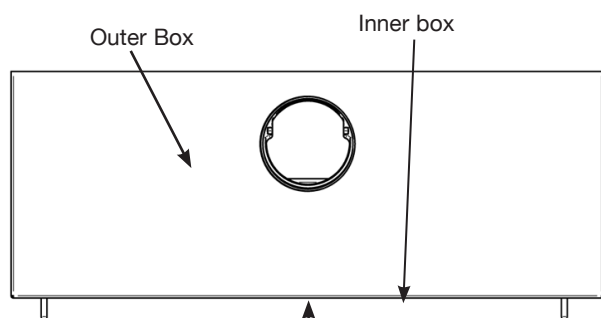

Ensure both boxes are parallel before tightening collar fixing bolts

Replace the internal components (baffle(s), door) following the Removing Internal Components Instructions section.

FITTING OF INTERNAL COMPONENTS

Once the inner box has been installed the internal components can be fitted.

The firebricks must be fitted before the baffle components.

FIREBRICKS

The Firebricks and Lower Baffle bricks are supplied in a box for safe transportation. It is advisable to carefully remove all of the bricks from the container in order to correctly identify the various types.

The side bricks have part of the Log bar supports attached. These must be fitted and removed at the same time as the bricks.

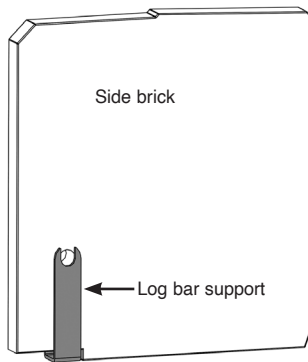

Install in the following order, see Diagram.
Take care when handling and do not force into position.

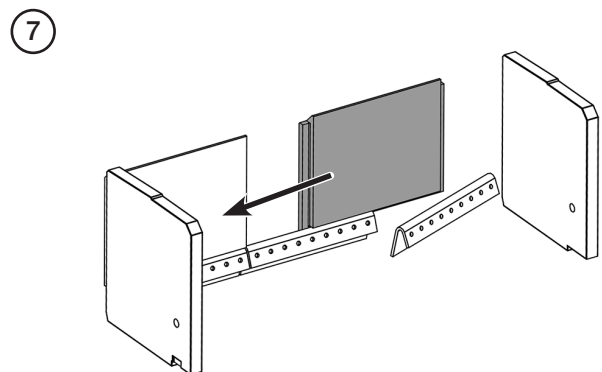
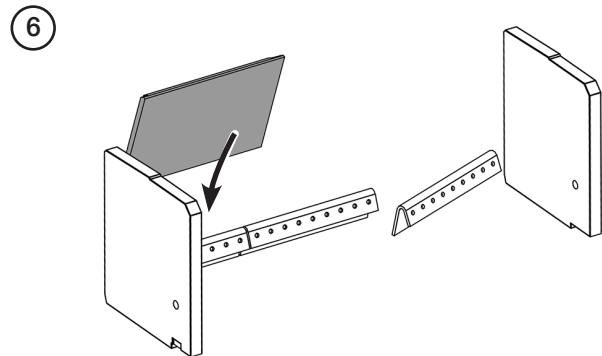
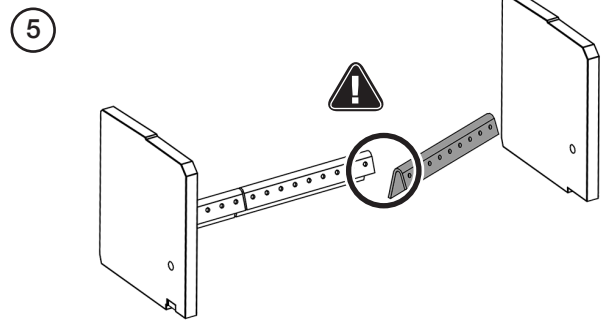
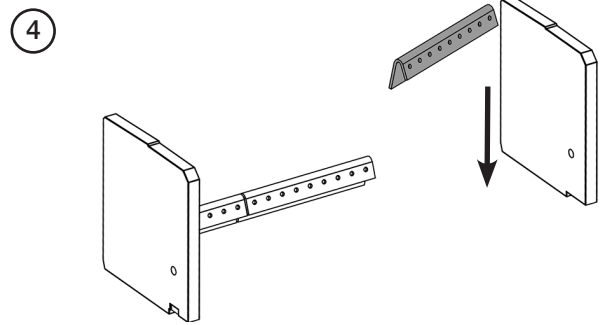
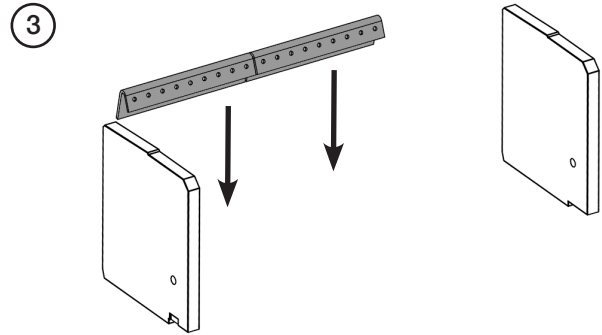
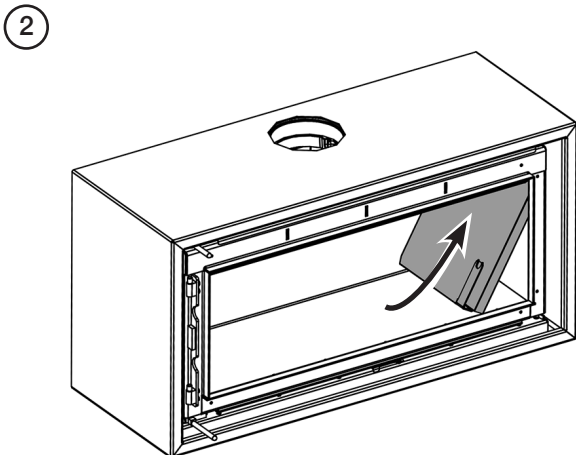
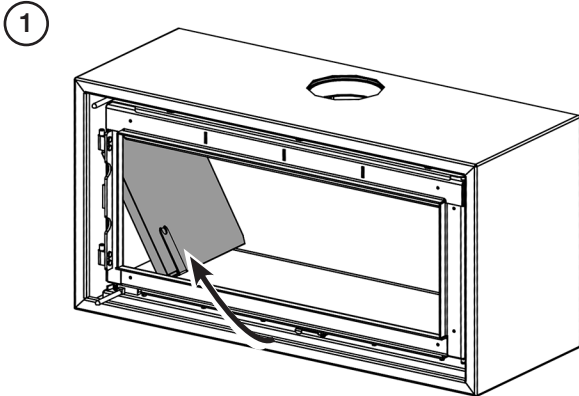

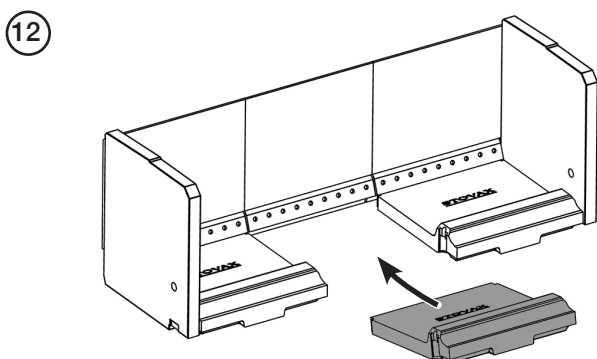
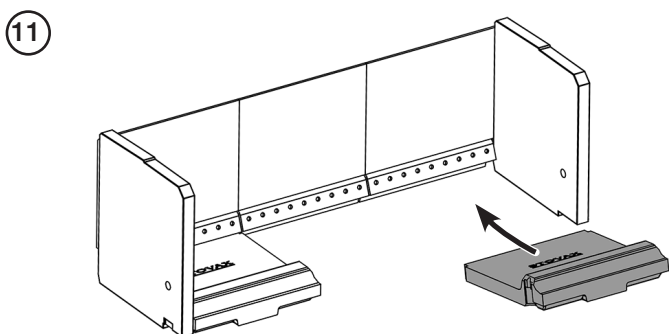
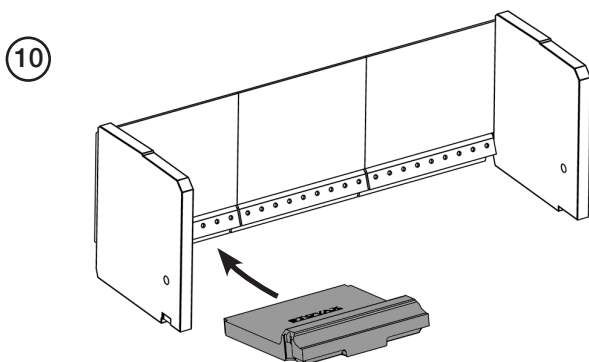
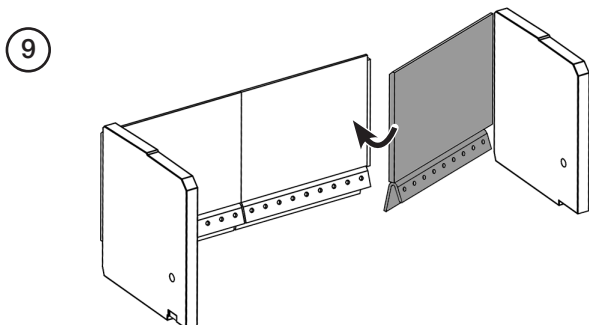
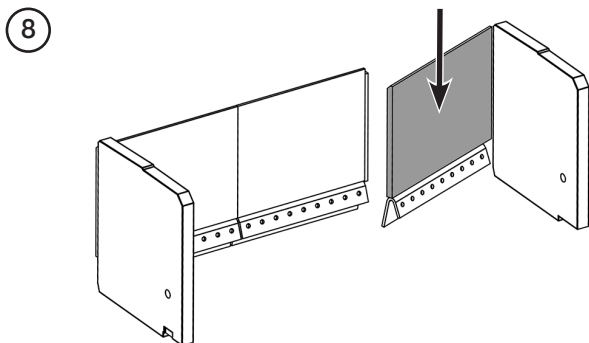

UPPER METAL Baffle

The appliance is fitted with 2 baffles in the top of the firebox to maintain efficient combustion.

Once the firebricks have been fitted it is possible to install the metal Top Baffles.

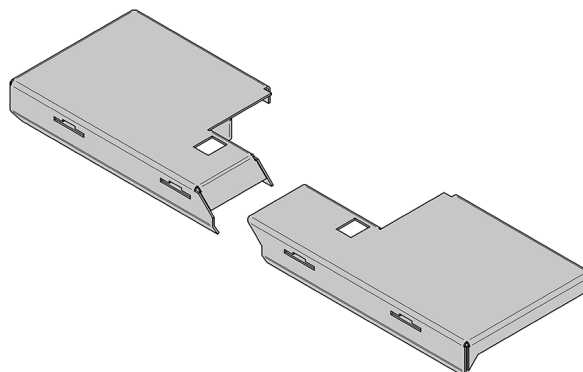

The Studio 2 baffle comes in two sections. Fit the right hand side baffle first. The method is the same for both sections.

Use two hands and place the rear edge of the baffle over the support pins at the back of the firebox. Raise the front so it is level and pull the baffle forwards to the front of the appliance and locate the keyslots in the front lip over the tabs at the top of the inner box.

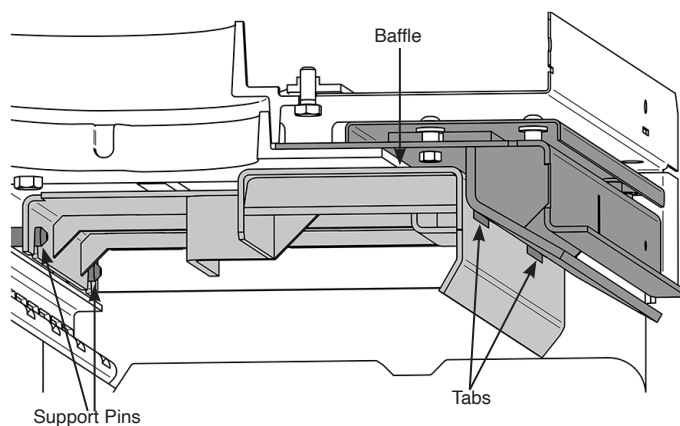

The baffle system is designed to give safe and efficient operation of the stove. Replace damaged baffles immediately.

Do not modify the baffle system.
Do not operate with the baffle system removed.

Do not modify firebricks.
Do not operate with firebricks removed.

LOWER BAFFLE BRICKS

The appliance is fitted with baffles in the top of the firebox to maintain efficient combustion.

To fit the Lower Baffle Bricks feed the Front Baffle Support bar into the appliance and rest on top of the side bricks.

This is best done by feeding one end of the bar towards the back of the firebox at an angle and then inserting the other end.

Once the support bar is inside the firebox bring forward as far as possible and place on the side bricks with the solid edge facing forward.

Insert the baffle bricks (see table) ensuring they are in the correct orientation..

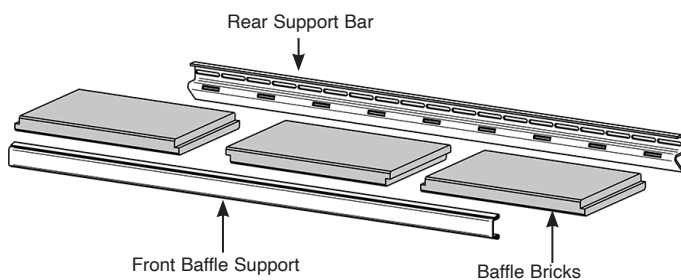

To do this:

- Rest the rear edge of the bricks on the support bar at the back of the firebox.
- Fit the two side bricks first, then insert the middle brick and support.
- Fit the Front Baffle Support over the front edge of the baffle bricks to hold in place.
- The Front Baffle Support

Do not modify baffle bricks.
Do not operate with baffle bricks removed.

LOG GUARD

Ensure that the side supports have been fitted at the same time as the side Firebricks

To fit the Log guard:

- Insert the Log Guard through the front of the appliance at an angle and rotate.
- With one end raised place the other end into one of the holes in the side bricks.
- Lower the Log Guard and insert the supports into the gaps between the base bricks and into the retaining brackets.

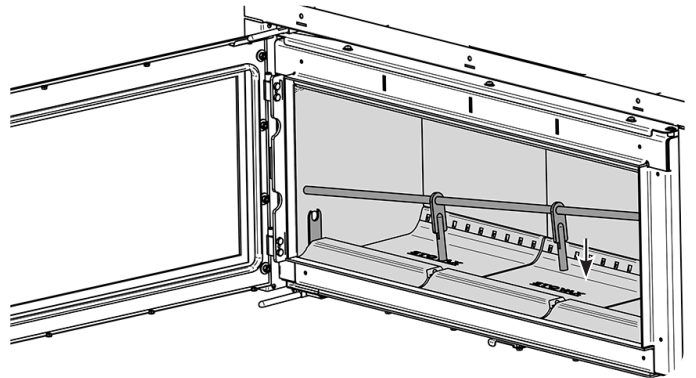

- Slide the Log Guard across so both ends locate evenly in the holes in the side bricks, see Diagram.

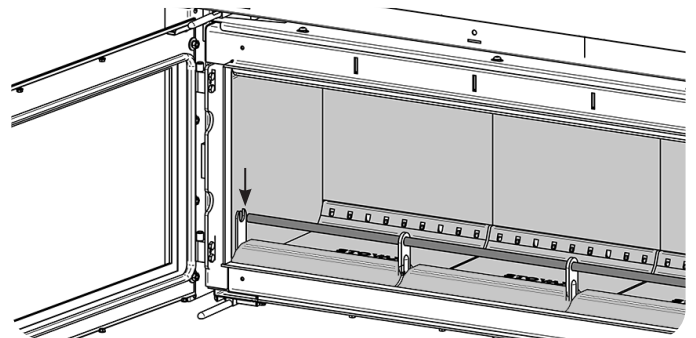

Do not use appliance without the log guard in position.

CO ALARMS

All open flued appliances can be affected by temporary atmospheric conditions which may allow fumes to enter the house. **It is recommended that whenever a new or replacement fixed solid fuel or wood/biomass appliance is installed in a dwelling a carbon monoxide alarm be fitted in the same room as the appliance.**

Provision of an alarm must not be considered a substitute for either installing the appliance correctly or ensuring regular servicing and maintenance of the appliance and chimney system.

It is also recommended that an optical smoke alarm or heat alarm should be fitted in a suitable location.

COMMISSIONING

To commission:

- Ensure all internal components (log guard, baffle(s), bricks) are correctly fitted.
- Check the door alignment and catch operation, adjust if required (see Maintenance and Servicing).
- Check the soundness of door seals, castings and flue connections.
- Check the operation of the air control.

Now carry out a final smoke draw test:

- First warm the flue with a blowlamp, or similar, for about 10 minutes.
- Place a smoke pellet on the centre of the base bricks, with the air controls open.
- Close the door. Smoke should now be drawn up the flue and be seen to exit from the flue terminal.
- Complete test with all doors and windows closed in the room where the appliance is fitted.
- If there are any extractor fans in adjacent rooms, the test must be repeated with the fans running on maximum and interconnecting doors open.
- Check the effect of ceiling fans during the test.

If the test fails, re-check the suitability of the flue system and ventilation. **An inadequate air supply to the room is potentially dangerous.**

- Light the appliance and slowly increase the temperature to normal operating levels.
- Ensure no combustion products enter the room.
- Open the main fire door when the appliance reaches normal operating levels and carry out a spillage test with a smoke match or pellet around the door opening.

If excessive spillage occurs:

- Allow the appliance to cool and re-check the flue system and ventilation.

Finally:

- **Explain the safe operation of the appliance and the use of the controls to the user and the importance of only using suitable fuels.**
- **Explain the cleaning and routine maintenance requirements.**
- **Explain the requirement to use a suitable fireguard when children, elderly or infirm persons are near the appliance.**
- **Record dealer/supplier details and installer details on page 3 of this manual.**

- **Record serial number in page 3 of this manual.** This number is required when ordering spare parts and making warranty claims.

- **Give this instruction manual to the customer.**

MAINTENANCE & SERVICING

ANNUAL SERVICE

Before the start of the heating season strip, inspect and clean the appliance as detailed:

- Allow appliance to cool.
 - Remove all internal parts: baffle, log guard and firebricks. Take care handling firebricks as they can become fragile after a period of use.
 - Sweep the appliance at this point if necessary.
 - Vacuum clean any remaining ash and debris from the inside of the appliance.
 - Check the parts for any damage. Replace any damaged parts using genuine Stovax replacements parts.
 - Check and clean the firebricks with a soft brush. Some surface damage will occur during use. The life of the bricks will depend on the type of fuels burnt and the level of use. **Replace damaged bricks as soon as possible.**
 - Re-fit cleaned internal parts.
 - **On appliances with printed glass do not use cleaning agents that have a high alkaline or acidic content, for example Stovax Gel Cleaner, these are aggressive cleaning agents designed to be used with heavily stained clear glass.**
- Do not use abrasive cleaners to remove tar or soot deposits from the glass.**
- Fit new door rope seal (see Maintenance and Servicing).
 - Lightly grease the door catch mechanism and hinge pins using high temperature grease such a graphite grease. Avoid getting grease onto the door seals and glass.
 - To refresh painted finishes a touch up spray is available. Contact your Stovax retailer quoting the serial number found on the appliance data badge.

Use genuine Stovax replacement parts to keep the appliance in safe, efficient working order. This is a list of the maintenance products that may need be required:

TASK	PRODUCT NAME
Preventing build-up of creosote in flue	Protector (15 sachets)
	Protector (1kg tub)
Sealing flue pipe joints	Fire Cement (500g tub)
	Fire Cement (600g cartridge)
Re-painting	Riva Midnight Black (150ml aerosol)
Protecting your hands	Heat resistant gloves
Thermic seal glue	(50ml bottle)

These products, available from your local Stovax dealer, along with regular maintenance and use of correct fuels, will keep the appliance in the best possible condition.

For more information about the Stovax Group products please visit our web site at www.regency-fire.com.au.

Burn at a low temperature for the first day of use after any maintenance. This allows the seals, fixing glues and paint to fully cure.

During this time the appliance may give off some unpleasant odours. Keep the room well ventilated to avoid a build-up of fumes.

Your Stovax dealer can carry out service and maintenance.

REMOVAL OF INTERNAL PARTS

To service and maintain the good working condition of your appliance it will be necessary to remove several internal parts. Consult the section for the following:

Door Assembly - Removing Internal Components Section.

Upper Baffles -Removing Internal Components Section.

Reverse the method of installation to remove the **Lower Baffle Bricks, Firebricks** and the **Log Guard** see Installation Section.

FITTING A NEW DOOR SEAL - ALL MODELS

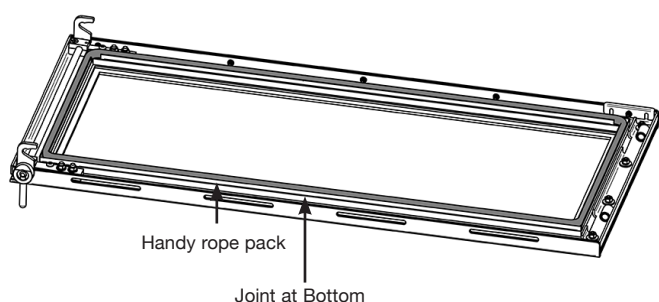

To maintain the safe use of your appliance you need to replace damaged or worn door sealing rope. To complete this operation remove the door, see the Removing Internal Components section.

Remove the old rope and scrape old glue from the locating groove. Clean the locating groove with a clean dry cloth to remove all old dust and debris.

Squeeze a generous bead of fresh Stovax Thermic Seal glue into the rope locating groove.

Press the new Stovax rope into the locating groove, placing the joint in the middle of the bottom edge of the door using tape supplied for the ends.

Refit the door and close the door to apply pressure to the new rope.

Leave the appliance closed for at least 12 hours before lighting the appliance and using at a low output for approximately one day.

Using the appliance with a damaged door seal can cause dangerous fumes to enter the room, or the appliance to over fire, resulting in damage.

ADJUSTING DOOR HINGES

To maintain the safe use of your appliance, you may need to adjust the door hinges to ensure the safe, correct closing of the door. The door must be horizontal/level with the top of the inner box and the door catch engages correctly.

Adjustment is possible in 2 places:

Door Hinge Assembly
Hinge Blocks on Inner Box

Open the door to give access to these 2 positions.

Door Hinge Assembly

Use a 10mm socket to slightly loosen the fixing nuts on the Door Hinge Assembly.

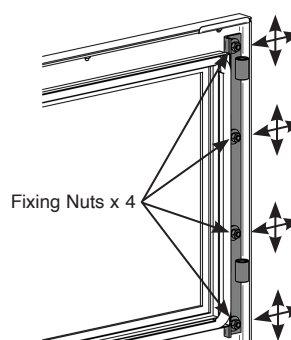

Loosening the Door Hinge Assembly allows for fine vertical and horizontal adjustment of the door position. This may require a trial and error approach to find the correct position. Ensure the door is horizontal before tightening the fixing nuts.

Hinge Blocks on Inner Box

Using a 10mm A/F spanner slightly loosen the fixing nuts inside the stove as shown in Diagram.

This will give vertical and horizontal adjustment which may need a trial and error approach to find the correct position. The door must be horizontally level.

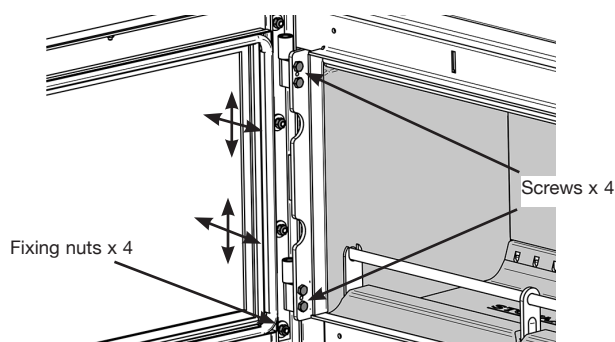

ADJUSTING THE DOOR CATCH

To maintain the safe use of your appliance you may need to adjust the door catch to ensure the safe, correct closing of the door. If the door hinges have been adjusted the door catch may need adjustment.

The catches are located at the top and the bottom of the right side of the door.

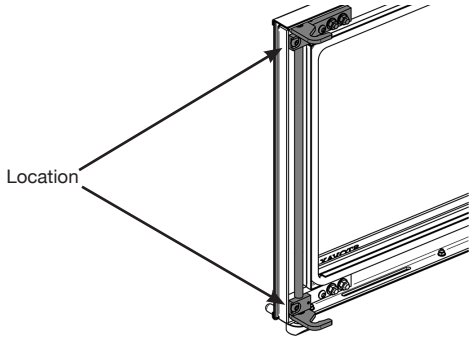

The top and bottom catches will need to be adjusted separately and in the same manner. The catch block can move in two directions.

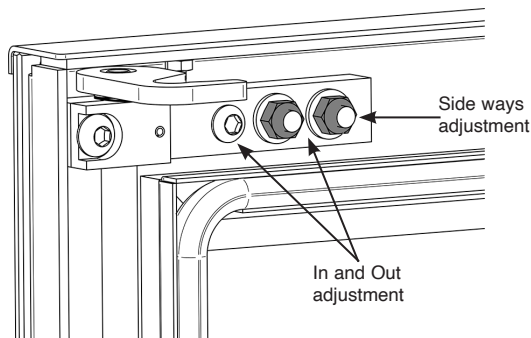

SIDEWAYS ADJUSTMENT

Using a 10mm A/F Spanner loosen the 2 nuts that hold the catch block to the door.

Do not remove the nuts completely.

This will allow some movement left or right to suit.

Tighten the nuts and recheck the catch operation.

IN AND OUT ADJUSTMENT

Loosening or tightening the M6 screw and the nuts on the catch block will cause the catch to move in or out from the door and allow the hook to gain better purchase on the door rollers.

Do not remove screw or nuts completely.

TO MOVE DOOR CATCH IN:

Loosen Nuts 1 & 2.

Wind screw **IN** until the Door Catch is in desired position.

Tighten Nuts 1 & 2 down to Catch Block.

View from above Appliance door

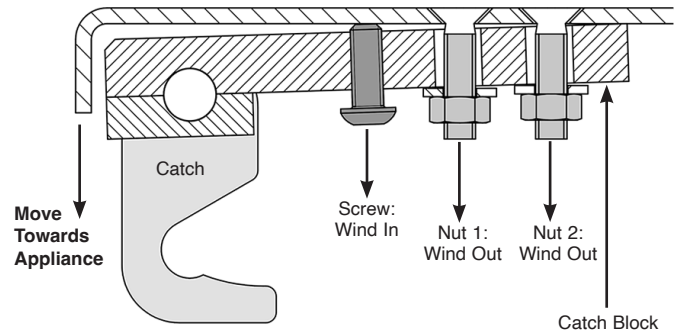

TO MOVE DOOR CATCH OUT:

Loosen Nuts 1 & 2.

Wind screw **OUT** until the Door Catch is in desired position.

Tighten Nuts 1 & 2 down to Catch Block.

View from above Appliance door

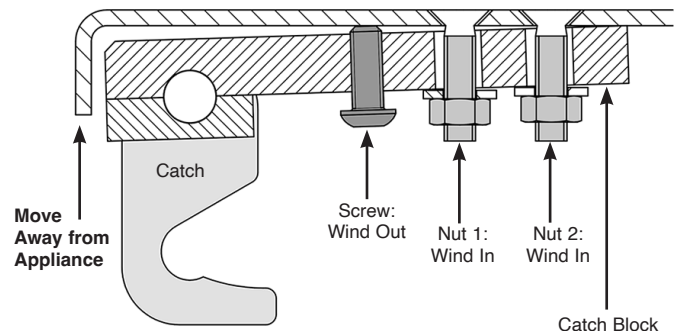

DO A PAPER TEST

To do a paper test shut a strip of paper in the door at the edges to test how well the rope seal stops the air from entering the appliance. If the paper can be pulled out easily then the seal is not sufficient and the rope must be replaced.

Repeat this around all the edges of the appliance.

REMOVAL OF THE FIREBRICKS

Depending on the model purchased it may be necessary to remove additional parts of the appliance when servicing to access the firebricks.

It is necessary to remove the Baffle Bricks and the side Upper Metal Baffles before attempting to remove the firebricks to avoid damage, see the Removal of Internal Components section.

Lift the side bricks slightly using the Log Guard support slots as finger holds; tilt the top of the side brick towards centre of the firebox and continue lifting to withdraw.

Remove the back bricks, then the base bricks.

LEGAL REQUIREMENTS

Before installation and/or use of this appliance please read these instructions carefully to ensure that all requirements are fully understood.

The appliance must be fitted by a registered installer*, or approved by your local building control officer.

It is very important to understand the requirements of the national Building Regulations and standards, along with any local regulations and working practices that may apply. Should any conflict occur between these instructions and these regulations then the regulations must apply.

Your local Building Control Office can advise regarding the requirements of the regulations.

Works must be carried out with care to meet the requirements of Health and Safety and comply with the Health and Safety rules, and any new regulations introduced during the lifetime of these instructions. Particular attention should be drawn to:

- Handling: The appliance is heavy. Adequate facilities must be available for loading, unloading and on site handling.
- Fire Cement: Some fire cement is caustic and must not come into contact with the skin. Protective gloves must be worn. Wash hands thoroughly with plenty of water after contact with skin.
- Asbestos: This appliance contains no asbestos. If there is the possibility of disturbing any asbestos in the course of installation seek specialist guidance and use appropriate equipment.
- Metal Parts: Take care when installing or servicing the stove to avoid personal injury.

A faulty installation can cause danger to the inhabitants and structure of the building.

For users of this appliance:

Your building insurance company may require you to inform them that a new heating appliance has been installed on your property. Check that your cover is still valid after installing the appliance.

HOW TO OBTAIN WARRANTY SERVICE

How to Obtain Warranty Service:

All appliances must be installed according to the installation instructions provided, and meeting all local codes and regulations. Any service call related to improper installation, operator error, mis-use and environmental issues will not be covered under warranty with no exceptions.

It is essential that any appliance that is damaged in any way should not be installed, and Regency notified of the extent of damage so the appropriate action can be taken to resolve the situation. Regency will not be accountable for any additional costs in the event of a damaged unit being installed.

The procedure required to submit warranty claims is listed below:

1. Customer shall contact the Selling Dealer with warranty claim with the warranty request.
2. The Selling Dealer will record the customer's details including names, address, contact numbers, the appliance type and brief description of problem.
3. Serial number must also be provided.
4. The Selling Dealer will complete a "Regency Request for Warranty Form" along with a copy of the customer sales order to verify date of purchase and forward this information to Regency Fireplace Products.
5. On receipt of warranty claim, Regency will process the claim and pass details on to the appropriate Technician.
6. Technician will contact the customer and make an appointment time.



*An installer licensed by the AHHA (Australian Home Heating Association) conforming to AS/NZS2918:2018 or by a licensed S.F.A.I.T installer in New Zealand

DESIGN PROTECTION

The Studio design, including its frames and accessories, are protected by European Design Registration
No. 001169338 0002 0008.

FLUE OUTLET POSITIONS

MINIMUM FLUE HEIGHT AS PER AS/NZS 2918:2018

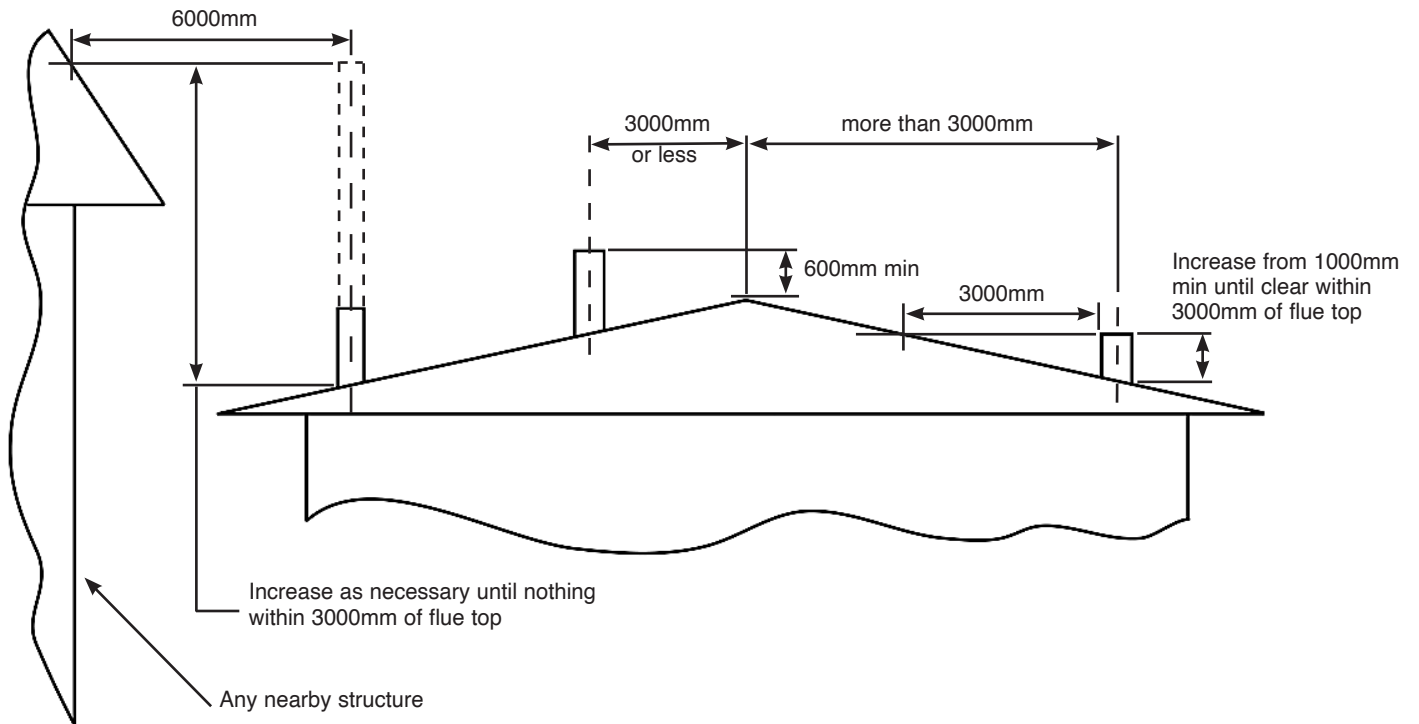
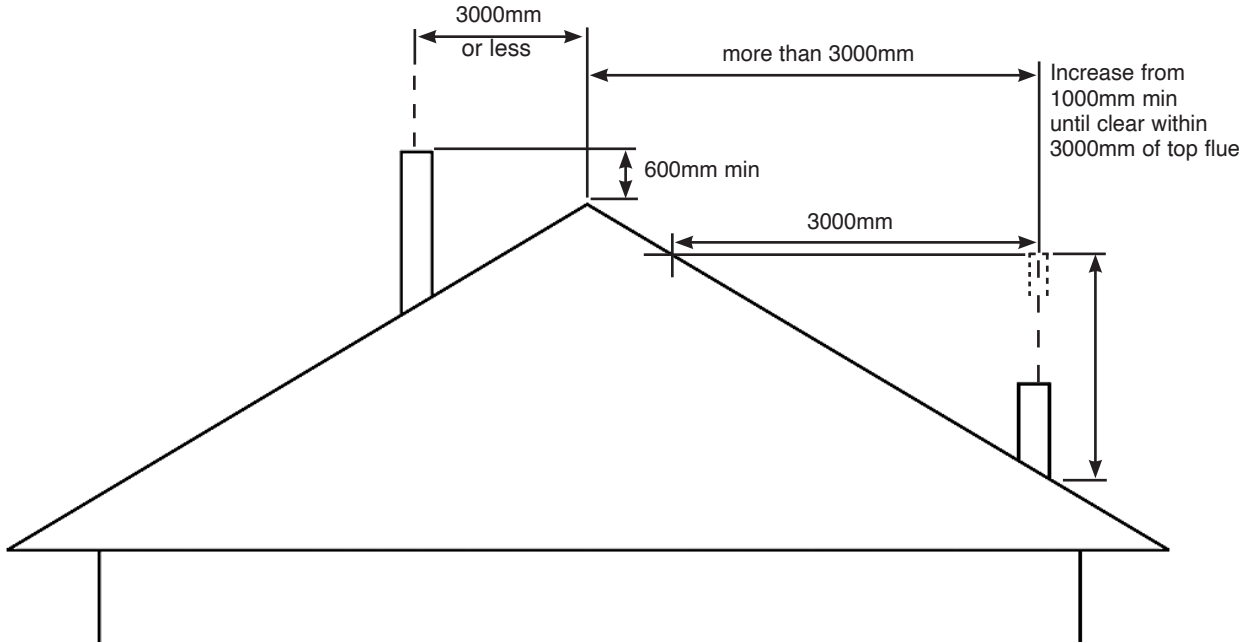

THE FLUE PIPE SHALL EXTEND NOT LESS THAN 4.6 M ABOVE THE TOP OF THE FLOOR PROTECTOR / HEARTH.

NOTE: INSTALLATION MUST BE CARRIED OUT BY A LICENSED INSTALLER IN ACCORDANCE WITH AS/NZS 2918:2018

TECHNICAL APPENDIX - FLUES

External Requirements
Refer to AS/NZS 2918:2018;4.9.1

AIR VENTILATION THROUGH CHIMNEY CHASE

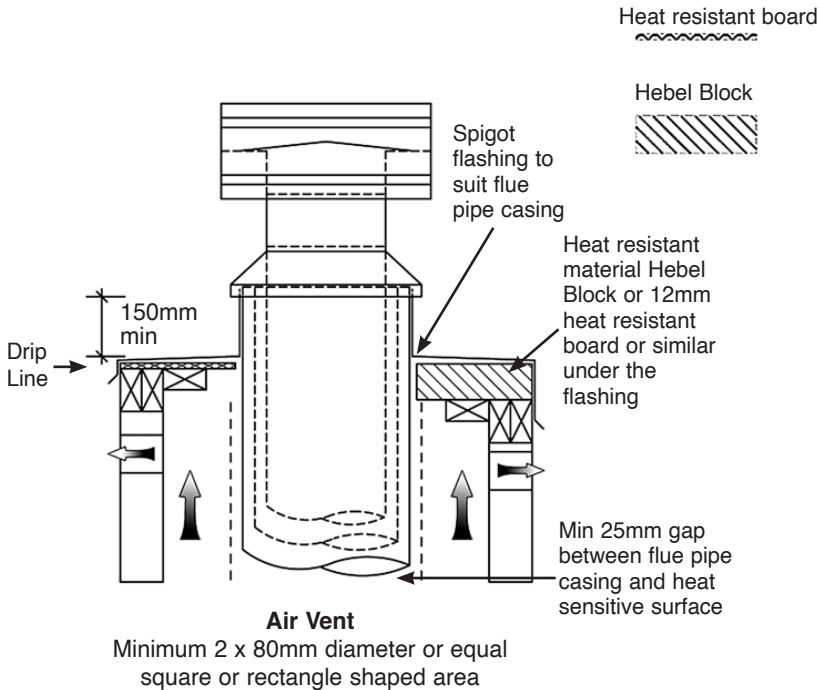

AIR VENTILATION THROUGH TOP FLASHING

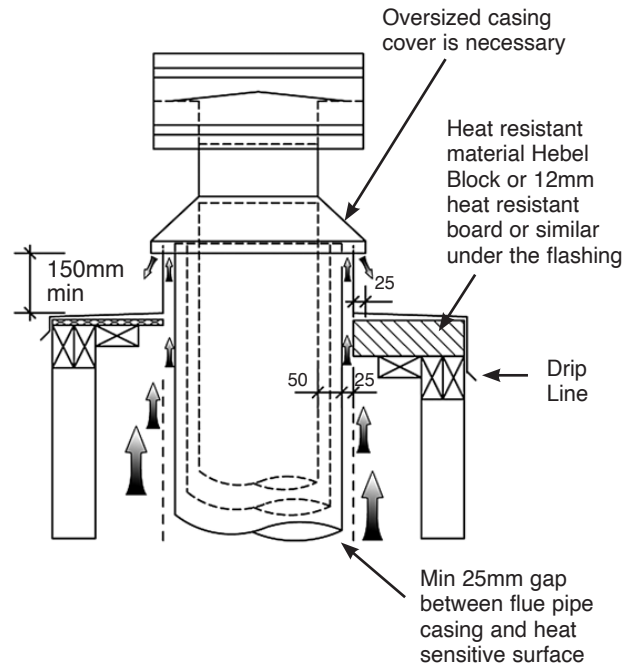

The flue system and its installation must comply with AS/NZS 2918:2018

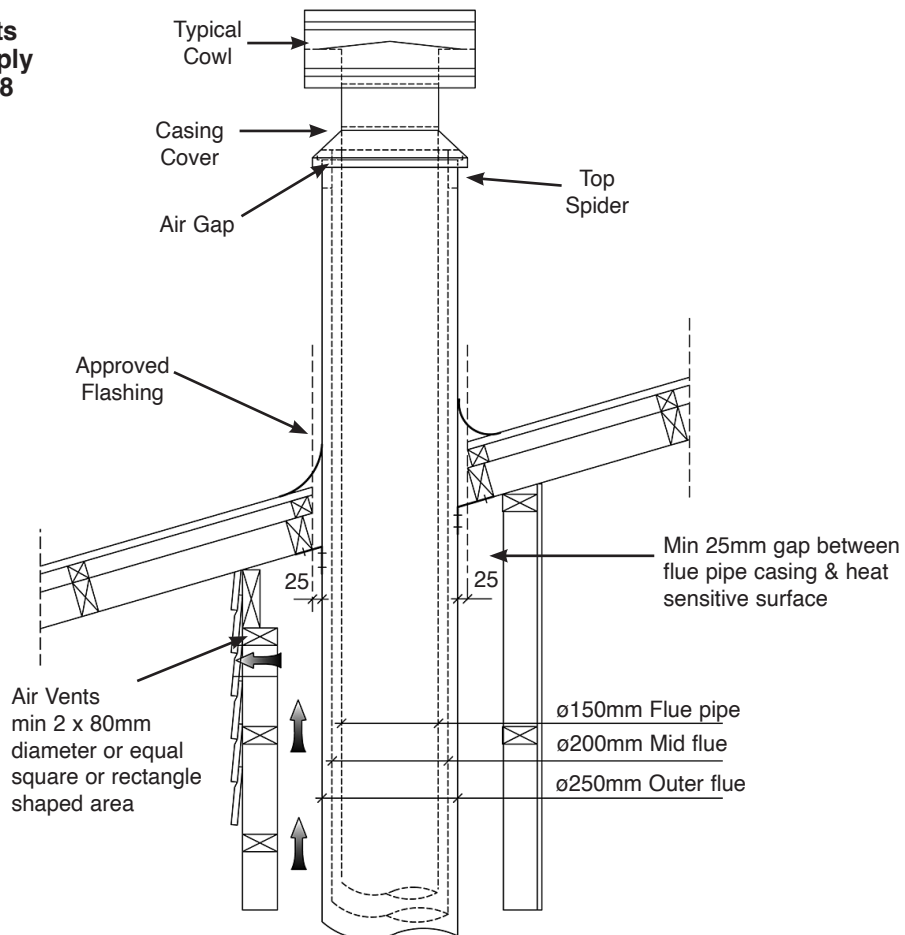

Note: All external air vents & ceiling penetrations must be bird & rodent proofed with permanently fixed screens

FLUES AND CHIMNEYS

WARNING: THE APPLIANCE AND FLUE-SYSTEM SHALL BE INSTALLED IN ACCORDANCE WITH AS/NZS 2918 AND THE APPROPRIATE REQUIREMENTS OF THE RELEVANT BUILDING CODE OR CODES.

WARNING: APPLIANCES INSTALLED IN ACCORDANCE WITH THIS STANDARD SHALL COMPLY WITH THE REQUIREMENTS OF AS/NZS 4013 WHERE REQUIRED BY THE REGULATORY AUTHORITY, I.E. THE APPLIANCE SHALL BE IDENTIFIABLE BY A COMPLIANCE PLATE WITH THE MARKING 'TESTED TO AS/NZS 4013'.

ANY MODIFICATION OF THE APPLIANCE THAT HAS NOT BEEN APPROVED IN WRITING BY THE TESTING AUTHORITY IS CONSIDERED TO BE IN BREACH OF THE APPROVAL GRANTED FOR COMPLIANCE WITH AS/NZS 4013.

CAUTION: MIXING OF APPLIANCE OR FLUE-SYSTEM COMPONENTS FROM DIFFERENT SOURCES OR MODIFYING THE DIMENSIONAL SPECIFICATION OF COMPONENTS MAY RESULT IN HAZARDOUS CONDITIONS. WHERE SUCH ACTION IS CONSIDERED, THE MANUFACTURER SHOULD BE CONSULTED IN THE FIRST INSTANCE.

The flue or chimney system must be in good condition. It must be inspected by a competent person and passed for use with the appliance before installation.

Products of combustion entering the room can cause serious health risks.

You must check the following:

- The construction of masonry chimneys, flue block chimneys and connecting flue pipe system must meet the requirements of the Building Regulations and the rules in force.
- A flexible flue liner system must be certified for use with solid fuel systems and installed to Building Regulations and the manufacturer's instructions. The flue liner must be replaced when an appliance is replaced unless proven to be recently installed and in good condition.
- If it is necessary to fit a register plate it must conform to the Building Regulations and the rules in force.
- Ensure the connecting flue pipe is kept a suitable distance from any heat sensitive material and does not form part of the supporting structure of the building.
- Make provision to remove the appliance without the need to dismantle the chimney.
- Any existing flue must be confirmed as suitable for the new intended use as defined in the Building Regulations and the rules in force.
- The flue or chimney systems must be inspected and swept to confirm the system is structurally sound and free from obstructions.
- If the appliance is believed to have previously served an open fire the chimney must be swept a second time within a month of regular use after installation to clear any soot falls that may have occurred due to difference in combustion levels.

- The flue exit from the building must comply with local building control rules.
- Do not connect or share the flue or chimney system with another heating appliance.

Do not connect to systems containing large voids.

You must provide suitable access to enable the collection and removal of debris.

You must sweep and inspect the flue when the appliance is installed. Note: the design of this appliance allows the chimney to be swept through the appliance.

The following must be adhered to:

AS/NZS 2918:2018:4.9.1

- a) The flue pipe shall extend not less than 4.6m above the top appliance.
- b) The minimum height of the flue system within 3m distance from the highest point of the roof shall be 600mm above that point.
- c) The minimum height of a flue system further than 3m from the highest point of the roof shall be "a minimum" 1000mm above roof penetration.
- d) No part of any building lies in or above a circular area described by a horizontal radius of 3m about the flue system exit.

N.B. in extreme wind areas it may be necessary to consult your local agent for further technical assistance.

- If flue is concealed in a chase, allow for air vents (2 x 80mm diam. or equivalent) at the highest possible point on the chimney chase or alternatively, allow a min 25mm air space between the casing cover spigot and the outer casing.

TECHNICAL APPENDIX - VENTILATION

VENTILATION

Increase air supply provisions where a room contains multiple appliances.

If vents open into adjoining rooms or spaces there must be an air vent of at least the same size direct to the outside.

Site the vents where cold draught is unlikely to cause discomfort. This can be avoided by placing vents near ceilings or close to the appliance (see diagram below).

Additional ventilation is required. This must be provided using a permanently open air vent, of the size listed, which is positioned so that it is not liable to be blocked both inside and outside the building.

i Allowances **MUST** be made for air replacement vents to be located near the fireplace to aid combustion. A minimum of one pair of air vents is recommended or one large vent. Allowance is to be made for a minimum of 2 inlet ducts from outside to internal vent location. **Note: DO NOT USE FIREPLACE CAVITY VENTILATION AS A METHOD OF AIR REPLACEMENT.**

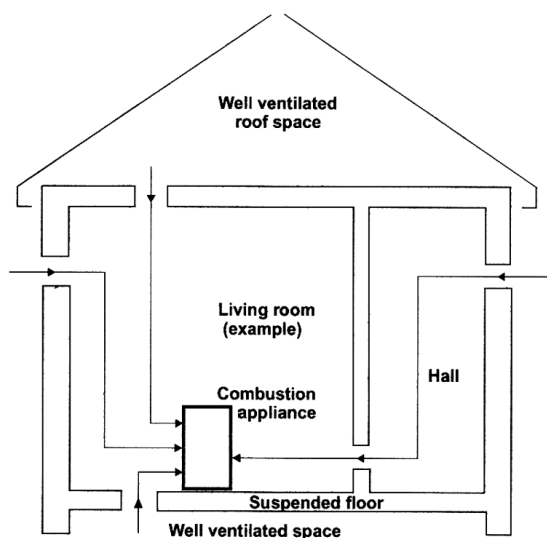

Extractor fans or cooker hoods must not be placed in the same room or space as this can cause the appliance to emit fumes into the room.

If any of these checks reveal problems do not proceed with the fitting of the appliance until they have been rectified.

MINIMUM DIMENSIONS - FLOOR PROTECTOR

If the appliance is installed directly onto the floor it must stand on a heat resistant constructional floor protector of the minimum dimensions shown and meet the requirements of AS/NZS 2918:2018, section 3.3.2.

The building must have a suitable load-bearing capacity for the floor protector and appliance. Consult a structural engineer for advice before proceeding.

When fitting into an existing floor protector check that the floor protector complies with current construction regulations and is at least the minimum sizes shown.

If there is no existing fireplace or chimney it is possible to construct a suitable heat resistant housing and floor protector setting. The flue must be installed in accordance with all local and national regulations and current rules in force.

FIRE SURROUND CLEARANCES

If the appliance is to be fitted with a fire surround use the **minimum** clearances (see Clearances Section) between any point of the appliance and any heat sensitive material.

We recommend you obtain expert advice before proceeding with work of this nature.

Some finishes may discolour with heat and some lower quality products may distort, or crack, when in use.

If stone / granite / marble or any other natural material is used to construct the fire surround, or any part of it, provision should be made for expansion and movement of the parts due to heating and cooling.

If you are in any doubt about the installation requirements, or suitability of fire surrounds contact your Stovax dealer.

All fire surrounds should be suitable for use with solid fuel heating products.

BASIC SPARE PARTS

RVFST-2HTAU STUDIO 2

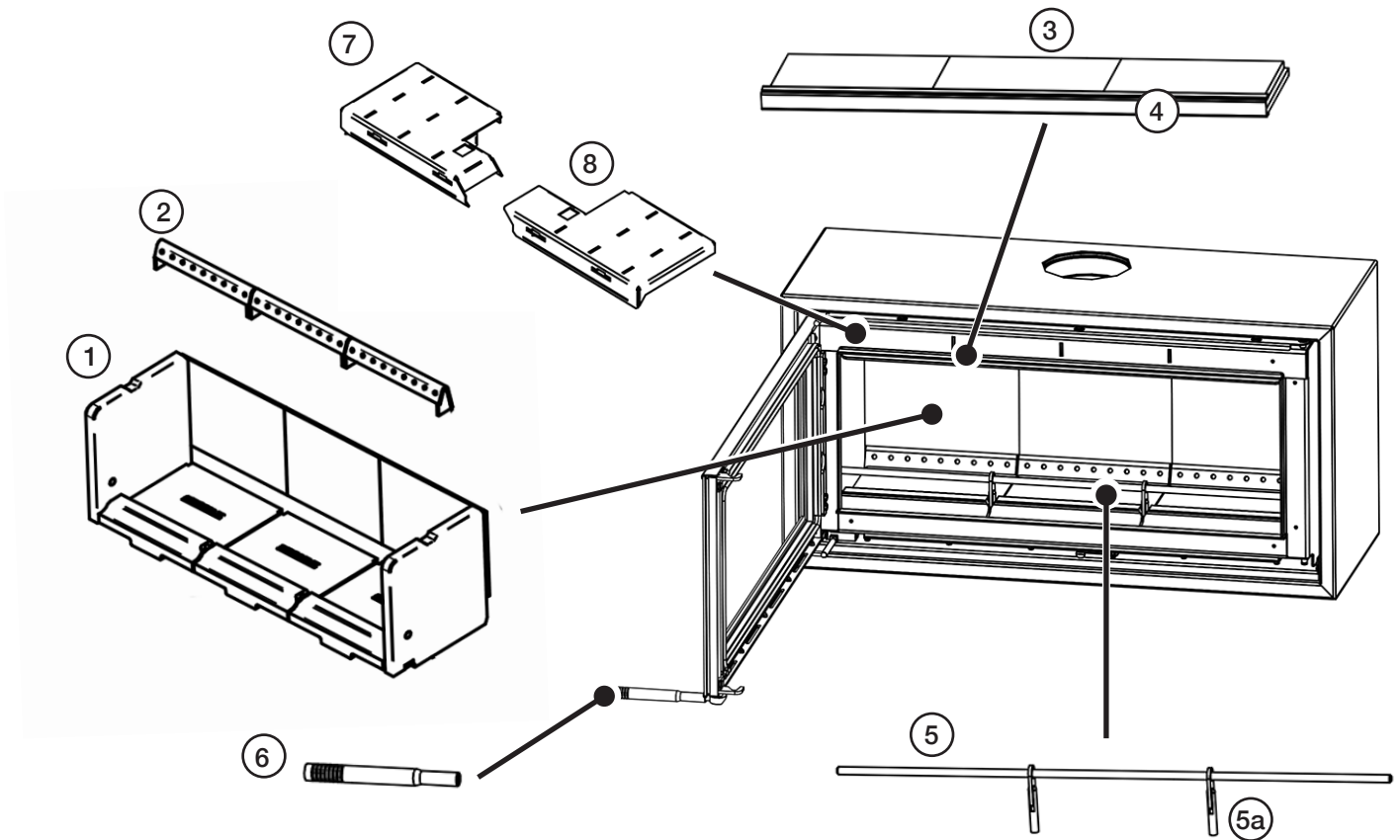

REF.	DESCRIPTION	CODE
		STUDIO 2
1	Brick Assembly	RVS-MEC10408
2	Steel Brick Set	RVS-MEC10589
3	Baffle Bricks	RVS-MEC12147
4	Baffle Brick Support	RVS-RA503452
5	Log Bar	RVS-ME601353
5a	Log Bar Support	RVS-MEC8500
6	Handle	RVS-ME600213
7	Top Baffle Left	RVS-MEC10102
8	Top Baffle Right	RVS-MEC10101

Due to continual technical improvements please check with your Stovax retailer for the most up to date parts lists.

BASIC SPARE PARTS - STUDIO 2 DOOR ASSEMBLY

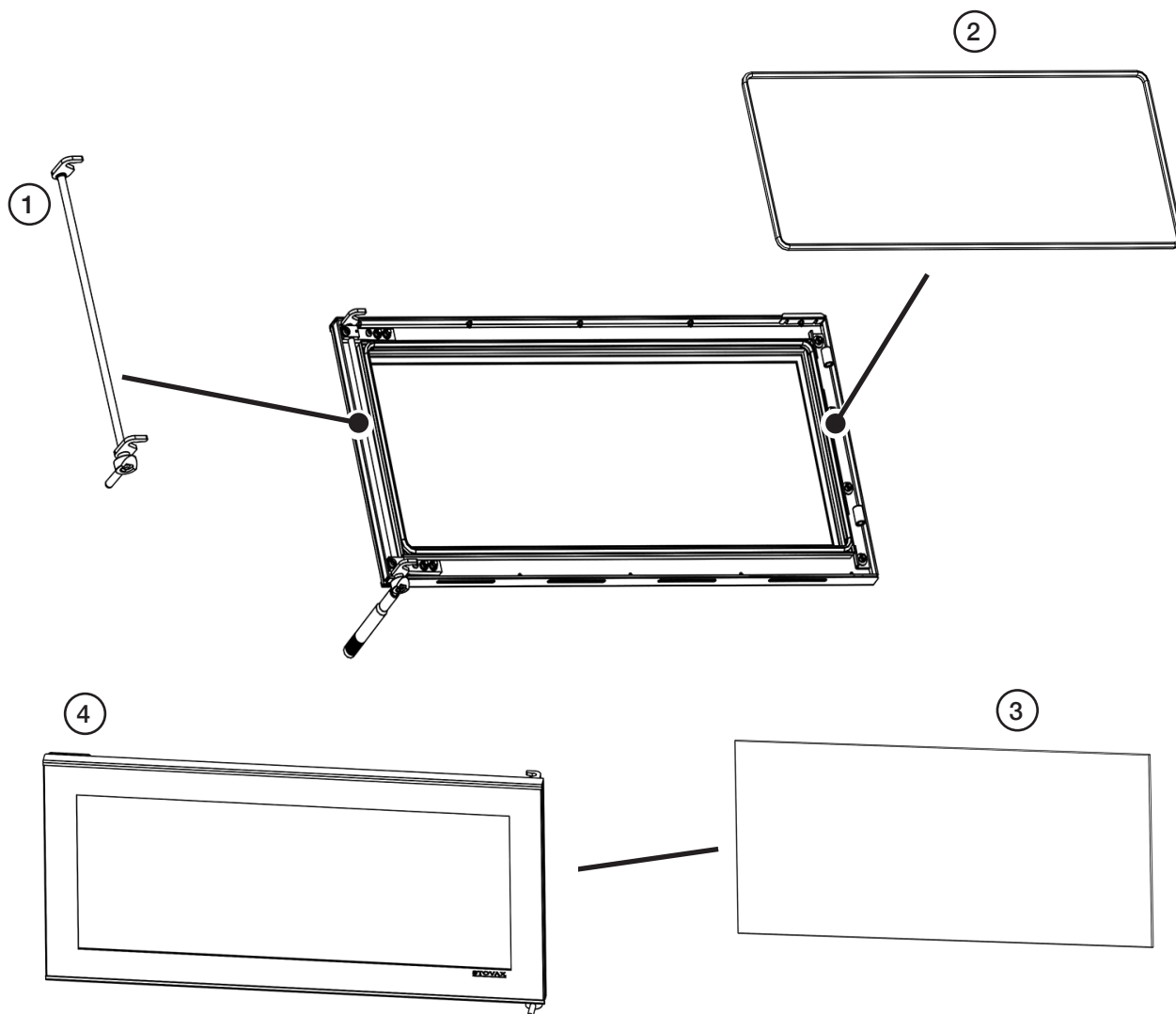

REF.	DESCRIPTION	CODE
		STUDIO 2
1	Door Catch Assembly	RVS-MEC10010
2	RopeSeal	5702
3	Door Glass	CE7477
4	Complete Door Assembly	RVS-MEC10103
	Glass Seal	5705

Due to continual technical improvements please check with your Stovax retailer for the most up to date parts lists.

SERVICE RECORDS

1ST SERVICE

Date of Service:.....

Next Service Due:.....

Signed:.....

Dealer's Stamp/SFAIT Registration Number/ AHHA

License Number

3RD SERVICE

Date of Service:.....

Next Service Due:.....

Signed:.....

Dealer's Stamp/SFAIT Registration Number/ AHHA

License Number

5TH SERVICE

Date of Service:.....

Next Service Due:.....

Signed:.....

Dealer's Stamp/SFAIT Registration Number/ AHHA

License Number

7TH SERVICE

Date of Service:.....

Next Service Due:.....

Signed:.....

Dealer's Stamp/SFAIT Registration Number/ AHHA

License Number

9TH SERVICE

Date of Service:.....

Next Service Due:.....

Signed:.....

Dealer's Stamp/SFAIT Registration Number/ AHHA

License Number

2ND SERVICE

Date of Service:.....

Next Service Due:.....

Signed:.....

Dealer's Stamp/SFAIT Registration Number/ AHHA

License Number

4TH SERVICE

Date of Service:.....

Next Service Due:.....

Signed:.....

Dealer's Stamp/SFAIT Registration Number/ AHHA

License Number

6TH SERVICE

Date of Service:.....

Next Service Due:.....

Signed:.....

Dealer's Stamp/SFAIT Registration Number/ AHHA

License Number

8TH SERVICE

Date of Service:.....

Next Service Due:.....

Signed:.....

Dealer's Stamp/SFAIT Registration Number/ AHHA

License Number

10TH SERVICE

Date of Service:.....

Next Service Due:.....

Signed:.....

Dealer's Stamp/SFAIT Registration Number/ AHHA

License Number

FPA WARRANTY STATEMENT

LIMITED WARRANTY

FPI Fireplace Products International Ltd. ("the distributor") through its wholly owned subsidiary, Fireplace Products Australia Pty Ltd and sold under the Stovax brand of fireplace products, extends this Limited Warranty to the original purchaser of this appliance provided the product remains in the original place of installation.

The items covered by this limited warranty and the period of such coverage is set forth in the table below.

Some conditions apply (see below).

The policy is not transferable, amendable or negotiable under any circumstances.

WOOD PRODUCTS	
Components Covered	Warranty
Welded Firebox Steel	2 years
All Stainless Steel Components, Smoke Deflectors, Heat Shields etc.	1 year
Door handle and latch assembly, all hardware	1 year
Glass Thermal Breakage Only	1 year
Steel Faceplates, Accessory Housings	1 year
All Plating	1 year
Ash Drawer, Heatshields, Pedestal	1 year
All Baffles-Steel, Ceramic, Vermiculite	1 year
All castings, firebox, surrounds, doors, panels etc.	1 year
All Electrical, Fans, wiring, switches etc.	1 year
Glass - Crazing	1 year
Firebricks	Nil

After the original warranty coverage for any of the parts above have expired, any repair and/or replacement parts purchased by the consumer from FPI or through an accredited distributor or dealer will carry a ninety (90) day warranty (valid only with an original copy of the tax invoice). No labor coverage is included with any repair and/or replacement part.

Replacement parts are limited to one per warranty term.

EXCLUSIONS

This Limited Warranty does not extend to paint, rust or corrosion of any kind due to a lack of maintenance or improper venting, combustion air provision, corrosive chemicals (i.e. chlorine, salt, air, etc.), firebrick (rear, sides or bottom), door or glass gasket, or any other additional factory fitted gasket.

Malfunction, damage or performance based issues as a result of environmental conditions, location, chemical damages, downdrafts, installation error, installation by an unqualified installer, incorrect chimney components (including but not limited to cap size or type), operator error, abuse, misuse, use of improper fuels (such as unseasoned timber, mill-ends, construction timber or debris, off-cuts, treated or painted timber, tea tree, metal or foil, plastics, garbage, solvents, cardboard, coal or coal products, oil based products, waxed cartons, compressed pre-manufactured logs), accidents, lack of regular maintenance and upkeep, acts of God, weather related problems from hurricanes, tornados, earthquakes, floods, lightning strikes/bolts or acts of terrorism or war, which result in malfunction of the appliance are not covered under the terms of this Limited Warranty.

FPI has no obligation to enhance or modify any unit once manufactured (i.e. as products evolve, field modifications or upgrades will not be performed on existing appliances).

Any unit showing signs of neglect or misuse will not be covered under the terms of this warranty policy and may void this warranty. This includes units with rusted or corroded fireboxes which have not been reported as rusted or corroded within three (3) months of installation/purchase. Any alteration to the unit which causes sooting or carboning that results in damage to the exterior fascia or over firing that can cause component or firebox/heat exchanger failure will not be covered by this warranty.

Units which show evidence of being operated while damaged, or with problems known to the purchaser and causing further damages will void this warranty.

Units where the serial no. has been altered, deleted, removed or made illegible will void this warranty.

Minor movement, expansion and contraction of the steel is normal and is not covered under the terms of this warranty.

Freight damages for products or parts are not covered under the terms of the warranty.

Porcelain/Enamel: Absolute perfection is neither guaranteed nor commercially possible. Any chips must be reported and inspected by the authorised selling dealer within three (3) days of installation. Any damage of this type not reported after this time period will be subject to rejection and any related warranty will not apply.

Special Finishes: Expect some changes in color as the product “ages” with constant heating and cooling. The manufacturer warranty does not cover tarnishing, changing colors and/or marks (i.e. finger prints, etc.) after the purchase of the product. Damage from the use of abrasive cleaners is not covered by warranty.

Products made or provided by other manufacturers and used in conjunction with the FPI appliance without prior authorisation from FPI may void this warranty.

INCORRECT INSTALLATION IS NOT COVERED BY WARRANTY. A SERVICE OR CALLOUT FEE WILL BE CHARGED IN THESE CIRCUMSTANCES.

LIMITATIONS OF LIABILITY

1. Exclusion of implied terms

The customer may have the benefit of consumer guarantees under the Australian Consumer Law. To the maximum extent permitted by law, all terms, conditions or warranties that would be implied into this Warranty or in connection with the supply of any goods or services by the supplier under law or statute or custom or international conventions are excluded.

2. Limitation of liability

(a) To the maximum extent permitted by law and subject to clauses 1 and 3, the supplier’s total liability arising out of or in connection with its performance or its obligations pursuant to this Warranty, or arising out of or in connection with the supply of specific goods or services (including pursuant to or for breach of this Warranty, under statute, in equity or for tort, including negligent acts or omissions) is limited as follows: (i) the supplier shall have no liability to the customer for any Consequential Loss; (ii) without limiting the effect of clause 2(a)(i), the supplier’s total aggregate liability for Loss, however arising, shall not exceed the GST exclusive aggregate price paid by the customer to the supplier for the specific goods or services that gave rise to the Loss in question.

(b) The limitations and exclusions in this sub-clause do not apply to the extent that any Loss is directly attributable to: (i) the personal injury or death caused by the supplier’s default, breach of this Warranty or negligence; or (ii) fraud by the supplier.

(c) Each party must take reasonable steps to mitigate any Loss it suffers or incurs.

3. Limitation of liability under Australian Consumer Law Guarantees

(a) To the extent that goods supplied by the supplier are not goods of a kind ordinarily acquired for personal, domestic or household use and the customer is deemed to be a consumer for the purposes of section 64A of the Australian Consumer Law, the customer agrees that the supplier’s liability for a failure to comply with a consumer guarantee that the customer may have a benefit under the Australian Consumer Law (other than a guarantee under sections 51 (title), 52 (undisturbed possession) and 53 (undisclosed securities)), is limited to, at the option of the supplier, one or more of the following: (i) replacement of the goods or the supply of equivalent goods; (ii) the repair of the goods; (iii) the payment of the cost of replacing the goods or of acquiring equivalent goods; or (iv) equivalent goods; or (v) the payment of the cost of having the goods repaired.

(b) To the extent that services supplied by the supplier are services other than services of a kind ordinarily acquired for personal, domestic or household use or consumption, the supplier’s liability for failure to comply with a consumer guarantee that the customer may have the benefit of is limited to, at the option of the supplier: (i) the supply of the services again; or (ii) the payment of the cost of having the services supplied again.

4. Subject to Change

This Limited Warranty is given at the time of sale and purchase of the relevant fireplace product. The terms of this Limited Warranty may be amended from time to time by FPI in accordance with changes to business practices, consumer laws or other legal requirements. The rights and protections granted under the Limited Warranty are those in force in relation to a fireplace product at the time and in the place of sale of that product, and only those terms will be applicable in respect of that product.

5. Severability

Any term of this Limited Warranty that is invalid or unenforceable in any jurisdiction is to be read down for the purposes of that jurisdiction, if possible, so as to be valid and enforceable, and is otherwise capable of being severed to the extent of the invalidity or unenforceability, without affecting the remaining provisions of this Limited Warranty or affecting the validity or enforceability of that provision in any other jurisdiction.

6. Definitions

For purposes of clauses 1, 2 and 3:

(a) Consequential Loss means loss of expected savings, loss of use, loss of opportunity, loss of profit, loss of revenue, increased financing costs, loss arising from delay, or any consequential, special or indirect loss or damage, whether or not the possibility or potential extent of the loss or damage was known or foreseeable, and whether arising from a claim under indemnity, contract, tort (including negligence), statute or otherwise.

(b) Loss means any expense, cost or damage of any kind and includes Consequential Loss and a fine or penalty imposed by a statutory or other authority.

Distributed by:

Australia

Fireplace Products Australia Pty Ltd
99 Colemans Road
Dandenong, South VIC, 3175
AUSTRALIA
+613 9799 7277
www.regency-fire.com.au

New Zealand

The Fireplace

Head Office & Showroom
12 Tawari Street
Mt Eden, Auckland, New Zealand
+649 623 6990
thefireplace.co.nz

Manufactured by

Stovax Limited, Spitfire Avenue, Skypark, Clyst Honiton, Exeter, Devon, England EX5 2FR
Tel: (01392) 474011 Fax: (01392) 219932 E-mail: info@stovax.com
www.stovax.com E & O E

A member of the Stovax Group
Adapted from English Issue 9 of PM452

